

Antenna Analyzer Notes

Greg Ordy, W8WWV
CTU, Contest University
Dayton, May 19, 2011

These Antenna Analyzer Notes were prepared for a Contest University session on May 19th, 2011.

Table of Contents

Introduction	1
SWR	3
Impedance Magnitude	4
Reference Plane	5
Calibration Testing	7
Broadband Detectors	9
Measurement Hints and Kinks.....	10
<i>Transmission Line Electrical Length and Velocity Factor</i>	<i>11</i>
<i>Signal Generator</i>	<i>11</i>
<i>Determining the Sign of the Reactance.....</i>	<i>11</i>
<i>Determining the Characteristic Impedance of a Transmission Line.....</i>	<i>13</i>
<i>Testing RF Transformers</i>	<i>13</i>
<i>Measuring Inductors and Capacitors.....</i>	<i>14</i>
<i>Return Loss.....</i>	<i>14</i>
<i>Dip Meter.....</i>	<i>15</i>

Introduction

The term *antenna analyzer* has been in the Amateur Radio vocabulary for approximately 20 years. When first introduced, it was a no more than a portable and self-contained SWR meter. Since SWR meters, powered by the normal radio

transmitter, were common inside stations for decades, the main feature of the antenna analyzer was the ability to take it outside to the antenna.

Portability was a game changer, since antennas are usually adjusted to minimize the SWR and it's simply faster and easier when you can bring an SWR meter close to the adjustment point on the antenna. The other choice would be to drag an 80 meter dipole inside the house, but that's not really practical. Even if you could bring the antenna close to the radio and SWR meter, the antenna should be adjusted in its normal operating position if at all possible.

An important part of the antenna analyzer evolution is the microprocessor. It serves as the coordinator between the analog blocks in the analyzer, a math engine for real number calculations, and manages the interactions with the operator, through a display and several controls. The earliest antenna analyzer that I am aware of had the following block diagram. Please note that this design *only* measures SWR.

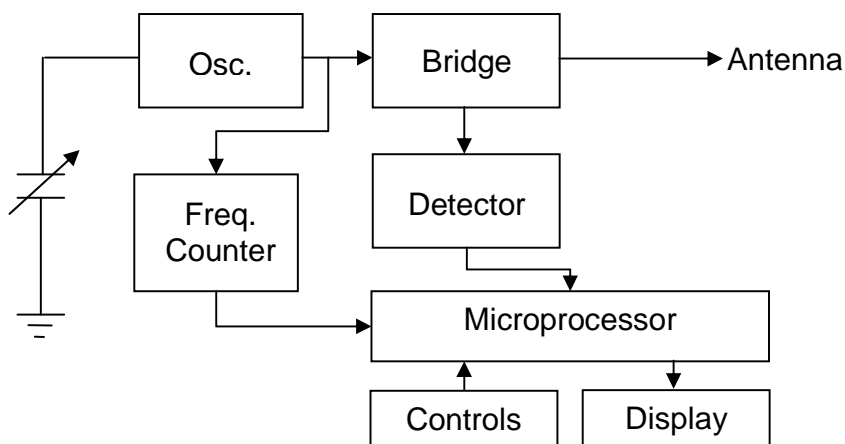

In some sense, an oscillator feeding a bridge is the same as a transmitter feeding an SWR meter in the traditional station. The oscillator was an analog device, and it was controlled with a variable capacitor, perhaps with band switching. Since the analyzer needed to know the operating frequency, a frequency counter chip was added to report the frequency digitally to the microprocessor. To get the most functionality from the chip, the frequency counter input was made directly available on the case. A more modern approach would be to have the microprocessor directly control a DDS (direct digital synthesis) chip in place of the analog oscillator. If your analyzer has a frequency counter input, and the frequency is set via a rotating knob, it's a good bet that this earlier approach is the architecture used.

The bridge feeds the SWR information to a detector. The voltages are presented to an analog to digital converter that typically has between 8 and 12 bits of resolution.

The microprocessor coordinates all of the blocks and interacts with the user. The normal mode of operation is to sample the frequency, read the detector A to D, compute the SWR, display the frequency and SWR, and then begin the process again.

SWR

The first electrical characteristic measured by the antenna analyzer was the SWR (standing wave ratio) on the transmission line connected to the analyzer. SWR is always measured relative to some system reference impedance, usually 50 Ohms. The reference impedance is often called Z_0 (Zee naught) in the documentation. If you want to work with an alternate impedance, perhaps 75 Ohms, you need to pay attention to the assumptions made by the devices, and adjust accordingly. Some analyzers allow you to redefine Z_0 , so that you don't have to perform your own conversions.

SWR is a convenient scalar value that measures the degree of mismatch in an antenna system. The minimum SWR value is 1, and indicates a perfect match. The usual goal of antenna adjustment or tuning is to minimize the SWR value.

The lore, conventional wisdom, and old wives tales are full of opinions about the value and importance of a low SWR. A good reference on the topic is the *Reflections III* book by Walt Maxwell, W2DU (www.w2du.com). All I'll mention here is that a low SWR is not a guarantee of a high performance antenna. As is often said, a dummy load has a very low and flat SWR, and it makes a very poor antenna.

One of the amazing characteristics of SWR is that it is not a function of transmission line length, so long as the line is ideal and lossless, and the same Z_0 as the analyzer. If you measure an SWR of let's say 1.68, and then insert 100 additional feet of lossless cable with the same Z_0 as the analyzer, your SWR should remain 1.68. If you add more lossless cable, the SWR is still 1.68.

Real cables, however, are lossy, and loss increases with added cable length, and with higher frequency. The quality of the cable usually determines the amount of loss.

The effect of loss is to lower the SWR as cable is added. One of the many Amateur Radio inside jokes asks, *how do you make a good dummy load for 432 MHz?* The punch line is to lay out a very long length of lossy transmission line and terminate it with *anything*. Given enough length, that is, enough loss, any

cable termination will be transformed into Z_o . Picking a higher frequency, such as 432 MHz, creates a dummy load with a relatively shorter cable.

In many cases, certainly on the HF bands, the effect of loss will be very small, unless the cable is very long and/or very lossy. So, for example, assume the SWR measured directly under an 80 meter dipole at some frequency is 1.75. From that junction point, an additional 150 feet of RG-213 cable is added to make it back to the station. The expected SWR in the station should drop to about 1.62. If the band was 10 meters, the SWR would drop to approximately 1.46. I made these estimates using the transmission line calculator program named *TLDetails*, by Dan Maquire, AC6LA. This is one of several programs that computes the effect of transmission lines on different loads. I find these programs to be quite useful, and seem to be always using them in conjunction with measurements.

While the SWR has dropped in this example, the mechanism to achieve the drop is loss, and that might not be what you prefer. In severe (high SWR) cases, it might be better to improve the match closer to the antenna and run a lower SWR down the longer line.

It is probably a good idea to have a rough idea of the expected SWR changes on your cable runs, especially those going into the station. In the example just presented, we saw the SWR drop from 1.75 to around 1.5, depending upon frequency, due to the 150 feet of added RG-213 cable. What happens if we measure an SWR of 1.1 or 2.0 inside the station? In other words, values that lie outside the range of reasonable expectations.

While there could be several explanations for that behavior, none are good news, and that includes the case of a lower than expected SWR. If the news is too good to be true, it probably is. One explanation might be that you ran over a cable with your lawn mower, and nicked the jacket, that then became water logged, compromising the cable. A second explanation is that the transmission line you added does not have the Z_o you think it has. Another explanation is that there is common mode or antenna current running on the cable, and the cable is acting as part of the antenna. That implies that it is radiating, which could lead to RFI inside the house. The usual solution for this problem is to add RF chokes to the cable. This problem is also discussed in the W2DU book.

Impedance Magnitude

After the success of the portable SWR meter, I suspect that there was a desire to add more functionality to the analyzer. The next obvious step is to measure the complex load impedance (resistance and reactance) that is equivalent to the measured SWR. Measuring complex impedance has traditionally been the domain of the expensive *vector network analyzer* (VNA).

I'm about to guess at the evolution of the antenna analyzer at this point, but I think it's a reasonable guess.

We start with a box that can measure SWR, which is a scalar or single valued quantity. That box was augmented with a second bridge that could measure the magnitude of the complex impedance. Magnitude means the square root of the resistance squared added to the reactance squared. Magnitude is also a scalar quantity, in units of Ohms.

It turns out that through a number of messy equations you can take SWR and impedance magnitude and compute resistance and reactance. For those interested in a graphical approach, it is the same as combining a Smith Chart with a Carter Chart. The Smith Chart contains a circle around the center that represents the set of impedance values with a constant SWR. The Carter Chart displays a family of curves with equal impedance magnitude.

Resistance and reactance is determined by the intersection of the SWR circle and the constant impedance magnitude curve.

Unfortunately, the circle intersects the curve at two points. You intersect once entering the circle, and a second time exiting the circle.

Those two points correspond to the resistance and reactance values, which can be read off of the Smith Chart. One point is $R + jX$ and the other point is $R - jX$. The problem is that we cannot tell which of the two is the correct answer!

This explains why there are many antenna analyzers on the market that measure resistance and reactance but cannot determine if the reactance is positive or negative. That is a consequence of **computing** resistance and reactance based upon **measured** SWR and impedance magnitude.

For many practical situations it is possible to know what the sign of the reactance is from the setup. For example if you are measuring a capacitor you know that the reactance is negative, and the analyzer can compute the equivalent amount of capacitance at that frequency. If you connect a capacitor to the analyzer but select inductance measurement mode, the analyzer will report the inductor value with the same magnitude of reactance as the capacitor at that frequency. This too can be useful if you are looking for the amount of inductance needed to resonate with the connected capacitor at that frequency.

When you get to measuring antennas, the lack of reactance sign resolution can be a bigger problem, but even in that case intelligent guesses can be made.

Reference Plane

I mentioned earlier that SWR values are largely unchanged by the length of the cable between the device or antenna being measured and the analyzer.

The same cannot be said for the impedance magnitude and the resistance and reactance that are computed from it. These values are very much a function of the length of the cable between the DUT (device under test) and the analyzer.

This difference has led to a lot of confusion.

The best way to sort out that confusion is to get comfortable with the term *reference plane*.

The reference plane is the point in a system where the measurement device has been adjusted or calibrated to make an accurate reading. Making a measurement at any other point will potentially introduce error.

When using equipment such as the classic VNA, it is necessary to begin a measurement with a calibration step that explicitly establishes the reference plane. This is usually the point where the different load standards are connected to the test jig. This *ritual*¹ makes it painfully clear to the user where they should connect the DUT.

With an antenna analyzer we don't have to perform a calibration step, we just turn it on and start measuring. In effect, the analyzer was precalibrated at the factory. This begs the question: *where is the reference plane?* The answer is that the reference plane is usually defined to be the point where the RF connector leaves the antenna analyzer case. That is the single point where the measured values are most accurate.

It just so happens that when measuring SWR, we can add additional low loss cable and introduce very little error into the measurement. Consider that to be a lucky accident due to the nature of SWR. That's one of the reasons SWR is popular – *it travels well*. For impedance, resistance, and reactance, however, we should make every attempt to attach the DUT directly to the reference plane. Any additional wires or cables added at that point will introduce error, possibly a lot of error.

The bottom line is that when measuring SWR, and scalar qualities directly related to SWR, such as *return loss*, a few extra feet of low loss cable with the Z_0 of the analyzer added to the analyzer input is not going to make a big difference in the measured results. For everything else, the results are most accurate when the DUT is connected to the analyzer with shortest wires right at the connector.

¹ Although explicit calibration might appear to be a waste of time, it allows the reference plane to moved and redefined. In many cases that is a powerful capability.

Another way to say it is that if the goal of a measurement is to obtain resistance and reactance values, then what you want to measure should be connected directly to the analyzer RF connector (the reference plane). The classic problem is that you want to determine the resistance and reactance of an antenna hanging in the air, and the only way that you can get to it is through a length of coax cable hanging down to the ground. In this case, the resistance and reactance values you measure through the cable are not going to be the same as the resistance and reactance at the antenna feed point, **unless** the transmission line is exactly $\frac{1}{2}$ wavelength long. That is a special case where the impedance on one end is transformed to the same value on the other end. If you must measure resistance and reactance through a transmission line, then you need to know the length and type of the line, and use a program such as TLDetails to compute what the load impedance is given a source impedance (and the line length and type). If you are careful and precise in your technique and calculations, this approach can produce good results, but it is more work.

One of the advantages of a device like the tradition VNA is that you can move the reference plane to the end of a length of quality transmission line, and make accurate measurements at a physical location that is otherwise hard to access directly.

When you can't move the reference plane, as in the case of the antenna analyzer, you have to physically move the analyzer and DUT together. SWR, however, does allow the rule to be broken, but that is a special case, not the general case.

Calibration Testing

Most analyzers have internal adjustments used for calibration and setting the reference plane. Over time and/or vibration and use, the calibration can drift, leading to measurement errors.

If your particular device has a procedure for checking the calibration, or even performing the calibration, then by all means follow those if there is any concern. In some cases, it is probably necessary to send the unit back to the factory for calibration.

If we wanted to check the calibration on our own, we would like a gizmo that could be adjusted to create any arbitrary complex impedance – that is, resistance and reactance values. This would allow us to simulate any load, and then see if the analyzer reported it correctly.

One simple load that I've used over the years is a variable resistor connected to a PL-259 plug using the shortest possible leads.



Figure 1 – Variable Resistor Load

I used #14 solid copper wires to provide a rigid mount for the potentiometer.

It is essential that the resistor be noninductive, since we are trying to provide resistance, not reactance. Even with short leads, the load will have increasing inductive reactance as the frequency climbs. My MFJ-269 analyzer reports 0 Ohms of reactance up through 30 MHz for this DUT (device under test).

When the load is purely resistive, the SWR is the ratio of the resistance divided by 50, or the reciprocal if the resistance is under 50 Ohms. This assumes a 50 Ohm system impedance.

Here are some examples of resistance values and the corresponding SWR. Again, this assumes no reactance in the load and a 50 Ohm system.

Resistance vs. SWR		
Resistance Ω	SWR	Ratio
200	4	200/50
150	3	150/50
100	2	100/50
75	1.5	75/50

50	1	50/50
40	1.25	50/40
25	2	50/25
20	2.5	50/20
10	5	50/10

I set the resistance using a typical Ohmmeter. The load is then attached to the analyzer, and the SWR can be checked. If the analyzer displays the load resistance, then the set value can be read directly.

Most real loads have nonzero reactance, so it is desirable to be able to check reactance as well. Perhaps the simplest way to create a known reactive load is to use 1% tolerance silver mica capacitors. They can be soldered to PL-259 plugs, again using the shortest leads possible, since the leads will act as inductors, and shift the value. Adding a known resistor value in series with the capacitor would create a series form load with both resistance and reactance.

Another clever way to create complex loads is to use a section of coax cable with a resistive load.

Broadband Detectors

Many if not most of the antenna analyzers have *broadband detectors*. This means that they will respond to RF energy over a wide frequency range. The assumption made by **all** measuring devices is that they are responding to energy under their control, and defined to be part of the measurement. Usually, that is energy at the single frequency of interest. When unwanted energy makes it to the detector, the results computed will be tainted by the extra signal.

The most common problem scenario is trying to measure a 160 meter antenna that is close (several miles) to an AM broadcast station. Depending upon the power levels and distances, a measurement at most any frequency supported by the analyzer might be problematic.

One solution is to use a measurement device with a narrow band detector. This sort of detector will exclude energy outside of the measurement range. Note that if there is sufficient unwanted energy **on the frequency of measurement**, no device, no matter how expensive and narrow band, will be immune to false readings.

A second solution is to use a filter designed to restrict the energy sent to the detector. One such filter is the MFJ-731.



Figure 2 – MFJ-731 SWR Analyzer Filter

Making an SWR/impedance measurement through a filter is not an easy task. Filters tend to color the magnitude and phase characteristics of their passband. The MFJ-731 is claimed to address those problems, and the controls have to be adjusted to set it correctly for each measurement. I must confess, I tried using the one shown here, and I never had much luck with it. I'm willing to consider it to be *operator error*, however, and I don't want to leave the impression that it is ineffective.

The potential problem with broadband detectors is another reason to have reasonable expectations for your measurements. If you are getting results that simply make no sense for what you are measuring, stop for a moment and consider if RF overload is a possible explanation.

Measurement Hints and Kinks

Most antenna analyzers can be used to perform a number of measurements, many that might not seem possible at first thought. This final section will list a

number of measurement scenarios. Much of this information comes from the manuals I've collected over the years for the analyzers I have here.

The ARRL Handbook in various recent editions has included a section on antenna analyzer tips and techniques. There are probably many Internet pages with useful information.

Some of the descriptions may use a feature not available on all analyzers.

Transmission Line Electrical Length and Velocity Factor

These measurements are so common that they are covered in detail in the documentation for each analyzer.

Signal Generator

An antenna analyzer is a signal generator. The power level is usually in the low milliwatt range. Some analyzers are not too stable, so precise receiver adjustment might not be possible if the analyzer drifts in and out of the passband.

A signal generator can be used to drive an antenna tuner. Adjust the tuner controls while watching the SWR on the antenna analyzer. It should be literally impossible to damage the analyzer, even if the SWR becomes very large. This can be a safe alternative to using the normal transmitter for tune up.

Determining the Sign of the Reactance

Many of the popular analyzers in use today report the reactance of a complex load, but cannot determine if the reactance is positive (inductive) or capacitive (negative). It is always reported as a positive number.

For many situations, the context determines the type of load reactance, and this restriction is not really a problem.

One of the harder contexts to understand is an antenna, and since we are talking about *antenna analyzers*, this is an important case.

Most antennas behave as if they are series resonant circuits. That means a resistor, and inductor, and a capacitor, all in series. The resistance is the radiation resistance. The inductor and capacitor reactance values are constantly changing with frequency, but at one frequency they are equal, and that is the frequency of resonance. The net reactance is zero at that frequency, since the inductive and capacitive reactance values balance and cancel each other.

Below resonance, the capacitive reactance is larger, and the net reactance is capacitive (negative). Above resonance the inductive reactance is larger, and the net reactance is inductive (positive). Consider the following example resistance and reactance graph of an antenna like a dipole or vertical, measured right at its feed point.

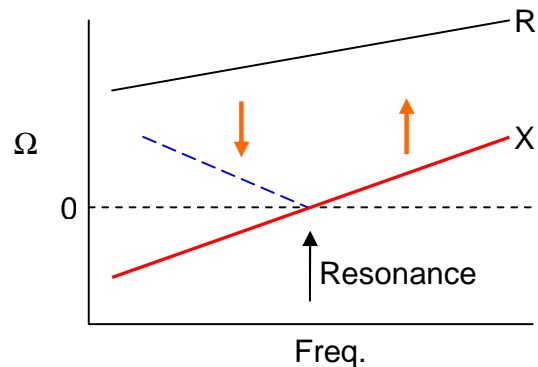

The reactance, X , (red) is negative below resonance, and then crosses over to positive at resonance. The antenna analyzer, however, only reports positive numbers. So, while the reactance is actually negative, the value on the display follows the blue dashed line. This is nothing more than the negative red line flipping over to the other side of zero Ohms.

We can understand which region we are in by increasing the frequency control and watching the behavior of the reactance. When the reactance is actually negative, what the display shows is a positive number that is dropping towards zero (blue dashed line). After touching zero (resonance), the value starts to climb again. So, the slope of the reactance line indicates if we are negative or positive reactance. A negative slope implies negative reactance, and a positive slope is positive reactance.

An important point to remember is that the antenna is only like a series resonant circuit at the feed point. If you measure it through a length of transmission line, the resistance and reactance are being transformed by the line action. At the length of $\frac{1}{4}$ wavelength (electrically), the resonance has been transformed from a series to a parallel form. This reverses the slope of the reactance curve. So, in order to use the method described for determining the sign of the reactance, you need to be sure that you are measuring a series reactance form. If it's parallel, you are going to get the wrong answer. Of course as mentioned before, measuring impedance through a transmission line is, in general, not going to produce correct answers unless you compensate for the effect of the transmission line.

Determining the Characteristic Impedance of a Transmission Line

When a transmission line is terminated with its characteristic impedance, it will transform that impedance to the input side at all frequencies. If the terminating resistor is not the same value as the line impedance, the input impedance will change with frequency.

To determine the impedance of a transmission line, connect the far end to a noninductive variable resistor with a wide enough range to include the line impedance.

While sweeping the frequency across the desired range, watch the SWR value. What you are looking for is a setting on the variable resistor that causes the SWR to be flat. The value of the SWR does not matter, but what does matter is that it stays the same value as you sweep the frequency. Continue to sweep the analyzer and adjust the variable resistor until you find the resistor value that produces a flat SWR across the frequency band.

If your analyzer displays resistance, then you can read the line impedance from the analyzer. If all you have is an SWR display, you can remove the variable resistor and measure its value with an Ohmmeter.

Testing RF Transformers

Most RF transformers have one side that is specified as 50 Ohms, and the other which may be different. For example, a 50 to 450 Ohm transformer intended to match a Beverage antenna. Let's call the 50 Ohm side the primary side, and the other side the secondary side.

When the secondary side is terminated with a resistive load equal to its impedance, the transformer will transform it to 50 Ohms on the primary side. You might say that the transformer is matched on both sides.

We can test a transformer using the following setup.

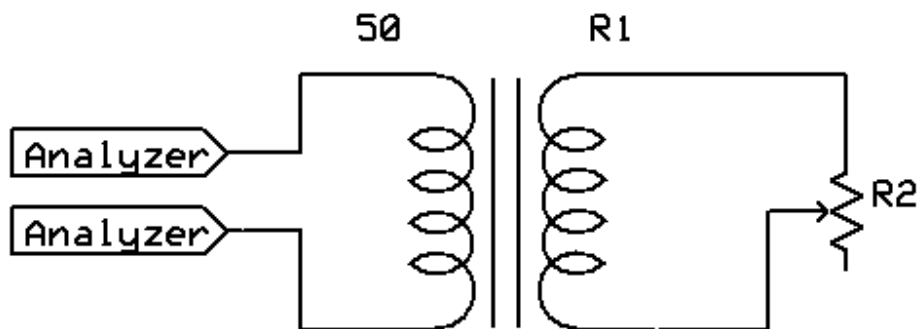

Figure 3 - Transformer Test Setup

This is a 50 : R1 transformer. Connect up a noninductive variable resistor to the secondary. Use the shortest wires possible to minimize any inductance.

While monitoring the 50 Ohm port on the analyzer, adjust R2 until the SWR dips to 1, which should also measure as 50 Ohms of resistance. This indicates a match on both sides of the transformer. At that point, remove the variable resistor and measure its value with an Ohmmeter. That value is the secondary side impedance.

This procedure will also work with a balun that is acting as an RF transformer. (for example, a 2 to 1 or 4 to 1 balun).

Measuring Inductors and Capacitors

The simplest way to measure the value of an inductor or capacitor is to connect it directly to the analyzer with the shortest possible leads. On the assumption that the part has a relatively high Q, the value being measured has a very low (near zero) resistance and then the reactance of the inductor or capacitor.

For some analyzers, the accuracy of the measurement improves if the resistance is not near zero. To exploit this, connect a 50 Ohm resistor in series with the inductor or capacitor and measure the combination. The resistance reported will be colored by the external resistor, but the reactance will be due to the inductor or capacitor, assuming that the lead length is kept short.

Return Loss

If your SWR meter has a high resolution (let's say 2 digits to the right of the decimal point), and can read as high as 20, you can determine the loss on a length of cable by converting the SWR into the *return loss*. Most devices with the required accuracy will do the conversion for you.

The idea behind return loss is that you send the signal from the analyzer down the transmission line, and because the line is terminated in either an open or a short, all of the energy will be reflected at the end, and be sent back to the analyzer. The amount of energy lost is due to the transmission line loss. The return loss is a measure of that loss. Since the loss takes place on a round trip down to the far end of the cable and then back to the analyzer, it is usually necessary to divide the return loss by 2 to determine the one way cable loss (at that frequency).

Dip Meter

An antenna analyzer can be used as a dip meter. All that is needed is a small coil that is used as a pick up. The MFJ-66 product is a pair of coils that provide two frequency ranges. It is possible to construct your own coil, although you will have to experiment with the size and number of turns.

As with all dip meters, the idea is to lightly couple to a (parallel) resonant circuit, such as an antenna trap. When you are at its resonant frequency, the circuit acts as a form of *RF sponge*, and draws power by magnetic coupling from the antenna analyzer coil. That draw is indicated by a drop in the SWR. After determining the approximate resonant frequency, the two circuits should be separated as much as possible (loose coupling) while still indicating a dip on the analyzer.

The MFJ-66 documentation includes several more measurement scenarios.